

WD-047

HEATER TUBE, 208V - 204252, 900W
 HEATER TUBE, 240V - 204253, 900W
 3.6 kW - SOCKET ENDS, NO WIRE LEADS.

REVISION			
REV	DATE	DESCRIPTION	APPROVED

NOTE: Heater tube sockets installed with opening facing down.

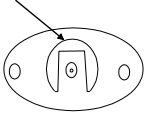
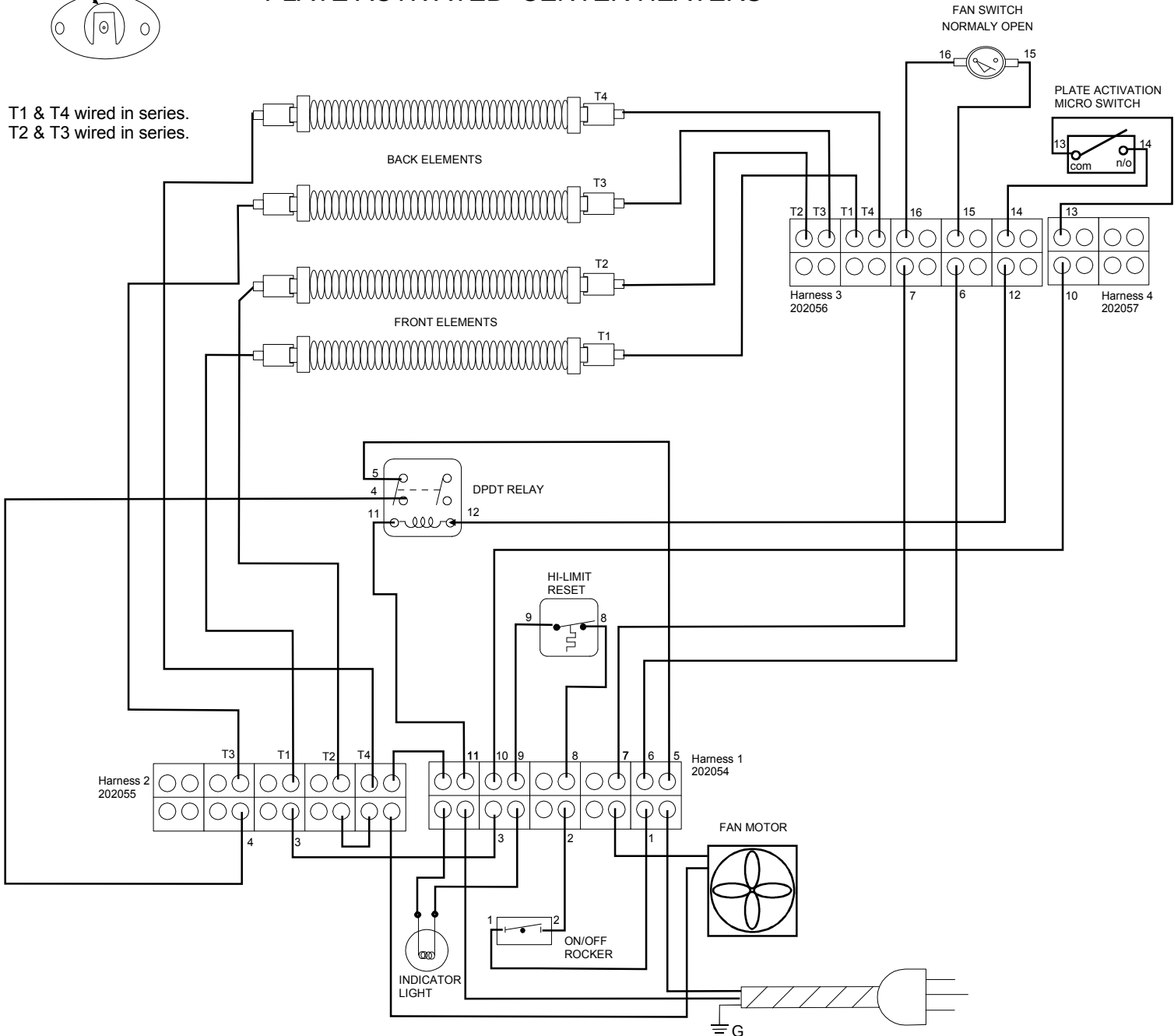

PLATE ACTIVATED CENTER HEATERS

T1 & T4 wired in series.
 T2 & T3 wired in series.



BELLECO INC. FOOD EQUIPMENT SPECIALISTS P. O. BOX 880 SACO ME 04072	DRAWN BY: MICHAEL CLAVET	WIRE DIAGRAM JW 30 CHEESE MELTER/BROILER SINGLE PHASE 208, 220, 240 VOLT
	DATE: 01/02/2014	